

*Mtn View Aviation*  
An AP Enterprises, LLC Company  
PO Box 31  
Hubbard, OR 97032

MVA-200C10M&O  
Installation and Maintenance Instructions for  
*Doot Steward*<sup>™</sup>  
In Accordance with STC SA01120SE

Contents

- Section A .      Installation Instructions
- Section B.      Maintenance, Inspection & Repair
- Section C.      Part Listing
- Section D.      Sample FAA Form 337

Approved for Release David L. Paradis

## SECTION A

### Installation Instructions

#### A. Introduction.

Insure that the intended aircraft is included in the eligibility of the STC. Installation to be accomplished by an FAA licensed Airframe Mechanic and inspected by an FAA licensed Airframe and Powerplant Mechanic with Inspection Authorization or by an FAA Part 145 Repair Station. Review all of the installation instructions before beginning the installation process. Pay particular attention to "NOTES". Inventory the kit prior to beginning to insure it is complete. Upon completion of the installation, an FAA Form 337, Major Repair and Alteration form will need to be completed and submitted to the FAA. A sample of the completed form is included in SECTION D. For questions, comments or problems with this installation please contact Mtn View Aviation, PO Box 31, Hubbard, OR 97032, Ph. (503) 981-4550, Fax (503) 980-3366, email [info@mtnviewaviation.com](mailto:info@mtnviewaviation.com). Please contact Mtn View Aviation for any in service problems or difficulties with this product.

#### B. Description of the Product.

The *Door Steward*<sup>™</sup> is a product improvement installation that greatly improves the operation of the aircraft doors. The installation consists of a gas spring attached to brackets mounted on the door and the airframe. When the door is unlatched the gas spring gently but firmly opens the door to the full open position. The gas spring while in the open position protects the aircraft and occupants from unexpected openings and closings by providing resistance to considerably higher wind gusts and prop wash than the original stops. In addition, the gas spring is extremely simple and reliable. The weight of each door installation is ½ Lb. The original door stops can either be removed or left on the door as long as they are operating properly and not interfering with the *Door Steward*<sup>™</sup>. Closing the door compresses the gas spring. The gas spring can easily be removed from its brackets to facilitate removal of the aircraft door, replacement of a defective gas spring or to conduct other maintenance.

#### C. Tools and Equipment Requirements.

1. Screwdriver, as required for interior removal.
2. Drill Motor, #30 hi-speed drill and drill stop.
3. 1/8" Clecos and Cleco Pliers
4. Cherrymax G-27 Hand Riveter or suitable equivalent
5. Deburring tool(s) and Hand files

#### D. Installation Steps.

1. Refer to the Aircraft Manufacturer's Maintenance Instructions for information regarding standard practices, precautions and notes.
2. It is the installer's responsibility to insure that this approved installation does not interfere or conflict with any other installed equipment or options previously installed on the aircraft.
3. Remove any installed door sill covers in the area where the airframe brackets will be installed. This will be the area on the forward lower door sill where it transitions from a horizontal sill to a vertical sill. If the area has carpeting installed, it will need to be pulled back or removed. It can later be reinstalled over and around the bracket.
4. On some aircraft, the aircraft data plate may be located close to where the left hand airframe bracket mounts. The data plate may need to be relocated slightly downward.
5. Remove or loosen any interior door panels to expose the area of the door where the door bracket will be installed. On most installations where there is an interior door panel, the door bracket will be located to extend out from the door at the very bottom of the door panel, thus eliminating any need to modify the existing interior door panel. If your door panels extend to the very bottom of the door covering the bulged perimeter of the door, you will want to use the included alternate door bracket, P/N 201C104-2 which does not have a ball stud attached to it from the factory. This door bracket extends out away from the door slightly further and you can create a simple slot in your interior panel. Once the bracket is installed and the interior is reinstalled you can mount a threaded ball stud, nut and washer to the bracket.
6. Locate the airframe bracket assembly, P/N 201C105-1, L/H or P/N 201C105-2, R/H onto the lower door sill and adjacent structure so that the ball stud on the bracket will be slightly higher than the intended location of the ball stud on the door bracket. The airframe bracket may need to be bent slightly to insure the bracket conforms as close as possible on both surfaces.

#### NOTE:

The completed installation must have the tube end of the gas spring slightly higher than the rod end so that seal lubrication is maintained on the end seal. If the gas spring is installed level, the end seal may not maintain lubrication and could result in a gradual loss of pressure in the gas spring. (Refer to picture 1.)



Picture 1.

(Note the airframe attach point is slightly higher than the door attach point.)

7. If the intended location of the airframe bracket covers an existing universal head rivet in the sill seam, remove the existing rivet so the portion of the bracket that extends over the sill lays flat. It is preferable to utilize all three holes in the sill portion of the bracket, but if there is a conflict or a problem with that portion laying flat on the sill, or lying across a large radius area of the sill, insure that at least two of the three attachment holes are utilized in the sill area. Insure the bracket conforms flat against both surfaces.
8. Using the airframe bracket as a template, locate and drill attachment holes with a #30 drill. It may be helpful to use a drill stop.
9. Debur the holes drilled in the airframe.
10. Install the airframe bracket using the provided CR3213 4-3 rivets.
11. Inspect the installation for security and proper installation of the rivets.
12. If the sill had a sill cover previously removed, it will be necessary to modify it to fit back in place around this bracket. Modify as needed and reinstall any sill cover. Modify as required and reinstall any carpeting earlier removed.
13. Temporarily install the tube end of the gas spring onto the mounted airframe bracket and install the rod end onto the uninstalled door bracket. (Use either the P/N 201C103-1 standard bracket with the riveted ball stud or if using the extended door bracket P/N 201C104-2 temporarily install the threaded ball stud with washer and nut.)
14. With the gas spring fully extended and the aircraft door at the desired full open position, (Typically  $\frac{1}{4}$ " –  $\frac{1}{2}$ " gap between the bottom of the door and the wing strut.) mark the location of the door bracket on the door. Insure it

is located low enough so the bottom of the bracket will just clear the bottom of any interior door panel. (Unless using the extended door bracket and you plan to slot the interior panel) Also check for the contact between the door and the gas spring when in your intended full open position. The gas spring can have slight contact with the door but avoid causing heavy contact with the door. Take into consideration any interior that may be reinstalled between the door and the gas spring.

15. Remove the door bracket from the rod end of the gas spring and review the marked location. Any interior attachment holes blocked or very near the door bracket can be abandoned as the gas spring and other attachment holes near the bracket will retain the interior panel in this area.



Picture 2.

**NOTE:**

If the door bracket is located toward the airframe bracket, the gas spring will try to extend the door further than the fully open position used to mark the door bracket. If you intend to retain the original aircraft door stops, this is not a problem. If using the *Door Steward*<sup>™</sup> to limit the door opening, insure it will not contact or damage any other structure such as the wing strut. Also the gas spring maybe put in a bind up against the door if located too close to the airframe bracket. Double check your intended location of the door bracket while attached to the gas spring to insure none of these problems will occur.

16. If satisfied with the door bracket location, use the door bracket as a template and drill all holes with a #30 drill. Only drill through the inner door panel. It may be helpful to use a drill stop.
17. Debur the holes drilled in the door.
18. Attach the door bracket using the provided CR3213 4-2 rivets.
19. Inspect the installed bracket for security and proper installation of the rivets.
20. **OPTIONAL:** If you regularly remove your doors you may want to utilize the alternate door bracket that you did not use in the installation as a stowing point for the gas spring when you remove the door. Simply remove the tube end of the gas spring from the airframe bracket leaving it attached to the door bracket and pivot the gas spring so the tube end of the gas spring is located near the aft end of the door. Using the uninstalled alternate door bracket install the tube end of the gas spring onto the door bracket and position it on the bottom of the door. (The gas spring when stowed, will be attached with the rod end to the door bracket

located about the middle of the door and the tube end of the gas spring will be attached the alternate door bracket located on the aft end of the door.) Use the door bracket as a template to mark its location on the aft part of the door. Install using blind rivets CR 3213 4-2 supplied.

20. Reinstall the interior door panel. If you used the extended door bracket, install the threaded ball stud, nut and washer after the interior panel that you slotted covers the door bracket.
21. Install the tube end of the gas spring on the airframe bracket and install the rod end of the gas spring on the door bracket. Insure any locking devices or safety clips are installed to securely lock the gas spring in place.



Picture 3.

#### E. Post Installation Inspection and Operation.

1. Operate the door through several opening and closings to insure smooth and proper operation. Close and latch the door and inspect the interior of the aircraft. Insure the gas spring is not going to hinder or interfere with the operation of the seats, seat belts or any other feature.
2. Open the door. Insure that in the open position the gas spring does not cause the door any unintended contact with other structure. It is normal for the airframe bracket to deflect slightly when the door comes to the full open position.
3. Inspect that in the open position that the gas spring is not significantly hindering entry and exit from the aircraft. The gas spring should be located parallel and very close to the open door.
4. If all inspections are satisfactory, proceed to the final steps.

F. Final Steps.

1. Install the supplied *Door Steward™ Equipped* decal to the exterior of the aircraft near the door latch assembly of the door(s) altered. The purpose of this decal will be to provide an indication that when the door latch is opened; the door will want to push open on its own.
2. Install the following SECTION B, Maintenance, Inspection & Repair Instructions and SECTION C, Parts List, in the aircraft maintenance records.
3. Complete the FAA Form 337, Major Repair and Alteration using the included sample in SECTION D, as a guide.
4. Complete the logbook entry in accordance with CFR 14 Part 43, Maintenance, Preventive Maintenance, Rebuilding and Alteration.

---

END

## SECTION B

### Maintenance, Inspection & Repair Instructions

For questions, comments or problems with this installation please contact Mtn View Aviation, PO Box 31, Hubbard, OR 97032, Ph. (503) 981-4550, Fax (503) 980-3366, email [info@mtnviewaviation.com](mailto:info@mtnviewaviation.com). Please contact Mtn View Aviation for any in service problems or difficulties with this product.

#### ATA Chapter 05      Time Limits/Maintenance Checks

05-00      General

The *Door Steward*<sup>™</sup> installation should be inspected during scheduled airframe periodic inspections that cover the door and door frame areas.

05-20      Scheduled Maintenance

Inspection of the installation will consist of the following:

1. Security of attachment of both airframe and door brackets to the associated structure.
2. Security of the gas spring attachment to the ball studs.
3. Security of the riveted ball stud to the airframe and door brackets.
4. Smooth operation of the gas spring. Inspect for evidence of end seal leakage or loss of gas spring pressure.

#### ATA Chapter 52      Doors

52-00      General

The *Door Steward*<sup>™</sup> is a product improvement installation that greatly improves the operation of the aircraft doors. The installation consists of a gas spring attached to brackets mounted on the door and the airframe. When the door is unlatched the gas spring gently but firmly opens the door to the full open position. The gas spring while in the open position protects the aircraft and occupants from unexpected openings and closings by providing resistance to considerably higher wind gusts and prop wash than the original stops. In addition, the gas spring is extremely simple and reliable. The weight of each door installation is ½ Lb. The original door stops can either be removed or left on the door as long as they are operating properly and not interfering with the *Door Steward*<sup>™</sup>. Closing the door compresses the gas spring. The gas spring can easily be removed from its brackets to facilitate removal of the



aircraft door, replacement of a defective gas spring or to conduct other maintenance.

1. Removal of the gas spring from attachment ball studs

On the all steel end fittings a safety clip may be installed as a secondary retention device. The safety clip must be removed before attempting to remove the gas spring. Grip the gas spring at the end fitting and pull it directly up off of the ball stud. Repeat for the opposite end.

2. Installation of the gas spring onto the attachment ball studs.

The all steel end fitting can be pushed onto the ball stud providing the safety clip is not installed. Push the end fittings onto the ball studs. The all steel end fittings come fitted with an internal circlip to capture the ball stud. Install the optional safety clip on the all steel end fittings, if so desired. The optional safety clip for the all steel end fittings provides a secondary positive retention to ensure the gas springs cannot come up off the ball stud.

3. Repair of a loose riveted ball stud in either the airframe or door bracket.

Using a Dremel or similar grinding tool remove the riveted end of the ball stud. Remove the ball stud. Inspect the bracket for security of attachment to the associated structure. Install P/N MVA9004, 1/4-20 threaded ball stud. Install washer and MVA9005-4 1/4-20 self-locking nut. Torque the nut to 80 in. lbs. Inspect the installation for proper seating of the ball stud in the hole and for full engagement of the nut on the stud.

4. Defective gas spring.

A gas spring which has lost pressure is not repairable. Replace defective gas spring with a new one with the same part number as removed. Gas spring end fittings which are damaged or worn can be replaced with new. Refer to the Parts List in SECTION C for the correct part number.

## SECTION C

### Parts List for 200C10 Installation

Item No.	Part Number	Description	Qty Reqd
	200C10-1	Installation Assembly, LH	Ref.
	200C10-2	Installation Assembly, RH	Ref.
1	. 201C101-1	Gas Spring Assembly	1
	. . 201C101-002	Gas Spring, Chrome or Nitrided Rod	1
	. . MVA-9001	End Fitting, All Steel	2
	. . MVA-200	Identification Label	1
2	. 201C103-1	Bracket Assembly, Door	1
3	. 201C104-2	Bracket, Door, Alternate and/or option	1
4	. 201C105-1	Bracket Assembly, Airframe, LH	1
	. 201C105-2	Bracket Assembly, Airframe, RH	1
5	. CR3213 4-2	Rivets, Blind	16
6	. CR3213 4-3	Rivets, Blind	11
7	. MVA-201	Decal, Door Steward Equipped	1
8	. MVA-9002-01	Safety Clip	2
9	. MVA-9004-01	Ball Stud, 10mm, 1/4-20 Threads	1
10	. MVA-9005-4	Locknut, Thin, 1/4-20	1
11	. NAS1149F0463P	Washer	1

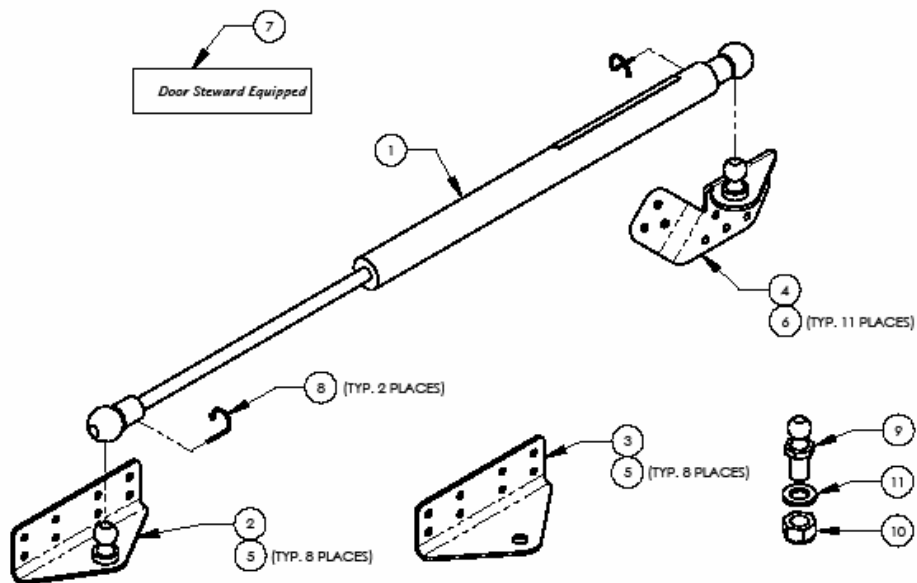

## SECTION D

SAMPLE FAA FORM 337



U.S. Department  
of Transportation  
Federal Aviation  
Administration

## MAJOR REPAIR AND ALTERATION (Airframe, Powerplant, Propeller, or Appliance)

Form Approved  
OMB No.2120-0020

For FAA Use Only

Office Identification

**INSTRUCTIONS:** Print or type all entries. See FAR 43.9, FAR 43 Appendix B, and AC 43.9-1 (or subsequent revision thereof) for instructions and disposition of this form. This report is required by law (49 U.S.C. 1421). Failure to report can result in a civil penalty not to exceed \$1,000 for each such violation (Section 901 Federal Aviation Act of 1958).

1. Aircraft	Make CESSNA	Model
	Serial No.	Nationality and Registration Mark
2. Owner	Name (As shown on registration certificate)	Address (As shown on registration certificate)

### 3. For FAA Use Only

### 4. Unit Identification

### 5. Type

Unit	Make	Model	Serial No.	Repair	Alteration
AIRFRAME	_____ (As described in item 1 above) _____				X
POWERPLANT					
PROPELLER					
APPLIANCE	Type				
	Manufacturer				

### 6. Conformity Statement

A. Agency's Name and Address	B. Kind of Agency	C. Certificate No.
	<input checked="" type="checkbox"/> U.S. Certificated Mechanic <input type="checkbox"/> Foreign Certificated Mechanic <input type="checkbox"/> Certificated Repair Station <input type="checkbox"/> Manufacturer	

D. I certify that the repair and/or alteration made to the unit(s) identified in item 4 above and described on the reverse or attachments hereto have been made in accordance with the requirements of Part 43 of the U.S. Federal Aviation Regulations and that the information furnished herein is true and correct to the best of my knowledge.

Date	Signature of Authorized Individual
------	------------------------------------

### 7. Approval for Return To Service

Pursuant to the authority given persons specified below, the unit identified in item 4 was inspected in the manner prescribed by the Administrator of the Federal Aviation Administration and is  APPROVED  REJECTED

BY	FAA Flt. Standards Inspector	Manufacturer	Inspection Authorization	Other (Specify)
	FAA Designee	Repair Station	Person Approved by Transport Canada Airworthiness Group	
Date of Approval or Rejection		Certificate or Designation No.	Signature of Authorized Individual	

## NOTICE

Weight and balance or operating limitation changes shall be entered in the appropriate aircraft record. An alteration must be compatible with all previous alterations to assure continued conformity with the applicable airworthiness requirements.

### 8. Description of Work Accomplished

(If more space is required, attach additional sheets. Identify with aircraft nationality and registration mark and date work completed.)

A/C:                      S/N                      A/C T.T.                      DATE:

INSTALLED DOOR STEWARD GAS SPRING DOOR ASSIST ALTERATION ON LEFT HAND AND RIGHT HAND CABIN DOORS IN ACCORDANCE WITH FAA APPROVED SUPPLEMENTAL TYPE CERTIFICATE NUMBER SA01120SE. WEIGHT CHG. NEGLIGIBLE. EQUIPMENT LIST UPDATED. STC Instructions for continued airworthiness added to aircraft records.

ATA CHAPTER 05                      TIME LIMITS/MAINTENACE CHECKS

05-00                      General

The Door Steward installation should be inspected during scheduled airframe periodic inspections that cover the door and door frame areas.

05-20                      Scheduled Maintenance

Inspection of the installation will consist of the following:

1. Security of attachment of both airframe and door brackets to the associated structure.
2. Security of the gas spring attachment to the ball studs.
3. Security of the ball stud to the airframe and door brackets.
4. Smooth operation of the gas spring. Inspect for evidence of end seal leakage or loss of gas spring pressure.

\*\*\*\*\* NOTHING FOLLOWS \*\*\*\*\*

Additional Sheets Are Attached